

4/2, 4/3 proportional directional valves, pilot operated, without electrical position feedback

RE 29115-XE-B2/2014-11
Replaces: 09.13

Type 4WRZ...XE...

Sizes 10, 16, 25, 32
Component series 7X
Maximum operating pressure of 350 bar
Maximum flow of 1600 l/min

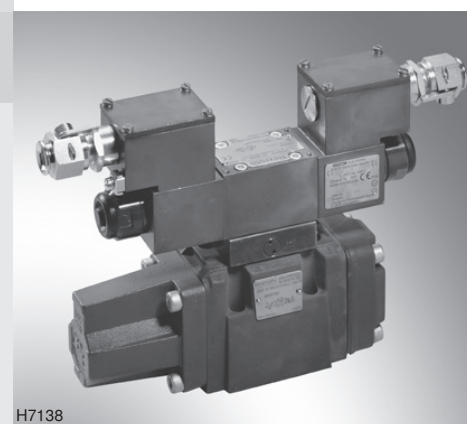

H7138

Actual product may differ

ATEX units
For explosive areas

Part II Data sheet



Information on the explosion protection:

- Area of application in accordance with the explosion protection directive 94/9/EC: **II 2G**
- Type of protection of the valve solenoid:
Ex e mb IIC T4 Gb according to
EN 60079-7:2007/EN 60079-18:2009

Special features of seawater-resistant valves

- The exterior of the valve housing is galvanized.
- The seawater resistance is defined by the ordering code "J".

What you need to know about these operating instructions

These operating instructions apply to the explosion-proof version of Rexroth valves and consist of the following three parts:

- Part I General information 07010-X-B1
- Part II Data sheet 29115-XE-B2
- Part III Product-specific instructions 29115-XE-B3

Operating instructions 29115-XE-B0

You can find further information on the correct handling of Rexroth hydraulic products in our publication "General Product Information on Hydraulic Products" 07008.

Table of contents

Contents	Page
Features	2
Symbols	2
Ordering code and scope of delivery	3
Function, section	4, 5
Technical data	6, 7
Information on the explosion protection	8
Control electronics	8
Electrical connection	9
Characteristic curves	10 ... 14
Dimensions	15 ... 18
Pilot oil supply	19

Features

- Pilot operated 2-stage proportional directional valves for controlling the flow direction and size
- Spring-centered control spool
- Actuation by means of the pilot control valve (3-way pressure reducing valve)
- Solenoid coil rotatable by 90°
- For subplate mounting:
Porting pattern according to ISO 4401 - ... (information depending on the size)
Subplates available in FE/ZN version (see pages 15 to 18)

Symbols (simplified)

with electro-hydraulic actuation

Type 4WRZ...-7X./...

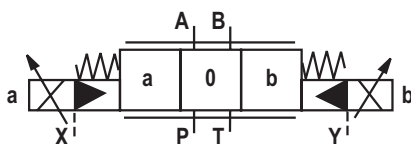

Pilot oil supply

X = external
Y = external

Type 4WRZ...A.-7X./...

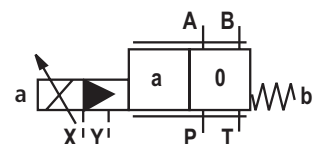

Type 4WRZ...-7X./...ET...

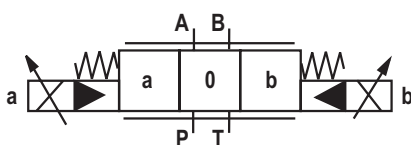

X = internal
Y = internal

Type 4WRZ...A.-7X./...ET...

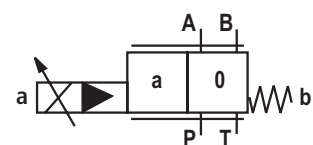

Ordering code and scope of delivery

4WRZ				-7X/6E		G24		XE		J		/D3			
Electro-hydraulic actuation	= Z													M = ¹⁾	NBR seals
Size														V =	FKM seals
Size 10	= 10													Important: Observe compatibility of seals with the hydraulic fluid used!	
Size 16	= 16													D3 =	with pressure reducing valve (fixed)
Size 25	= 25													Pilot oil supply and return	
Size 32	= 32													No code =	External pilot oil supply External pilot oil return
Symbols														E =	Pilot oil supply internal Pilot oil return external
														ET =	Internal pilot oil supply Internal pilot oil return
														T =	External pilot oil supply Internal pilot oil return
														Surface protection Seawater-resistant, galvanized	
														J =	
														XE =	Explosion protection, "increased safety", for details, see information on the explosion protection, page 8
														Supply voltage of the control electronics	
														G24 =	24 V direct voltage
														6E =	Proportional solenoid
														7X =	Component series 70 to 79 (70 to 79: unchanged installation and connection dimensions)
														Rated flow	
														25 =	25 l/min (size 10)
														50 =	50 l/min (size 10)
														85 =	85 l/min (size 10)
														100 =	100 l/min (size 16)
														125 =	125 l/min (size 16)
														150 =	150 l/min (size 16)
														180 =	180 l/min (size 16)
														220 =	220 l/min (size 25)
														325 =	325 l/min (size 25)
														360 =	360 l/min (size 32)
														520 =	520 l/min (size 32)
														Characteristic curves, see pages 10 to 14	

Included in the scope of delivery:

Valve operating instructions with declaration of conformity in part III

¹⁾ suitable for mineral oil (HL, HLP) according to DIN 51524

Function, section

Pilot control valve type 3DREP 6...

The pilot control valve is a 3-way pressure reducing valve that is actuated by a proportional solenoid. It converts an electrical input signal into a proportional pressure output signal and is used for all valves of type 4WRZ ...

The proportional solenoids are controllable wet-pin DC solenoids. The solenoids are actuated by external control electronics.

Set-up:

The valve basically consists of:

- Housing (1) with connection surface
- Control spool (2) with pressure measuring pins (3 and 4)
- Solenoids (5 and 6) with central thread

Functional description:

The pressure in A or B is set by means of the proportional solenoids. The pressure depends on the current.

With de-energized solenoids (5, 6), the control spool (2) is held in the central position by means of the compression springs (8). Ports A and B are connected with T so that the hydraulic fluid can flow off to the tank without obstructions.

By actuating a proportional solenoid, e.g. solenoid "b" (5), the pressure measuring pin (4) and the control spool with it (2) are moved to the left. This opens the connection from P to A and B to T via orifice-type cross-sections with progressive flow characteristics. With the surface of the pressure measuring pin (3) the pressure that builds up in channel A acts on the control spool and against the solenoid force. The pressure measuring pin (3) is supported by the solenoid "a". If the pressure exceeds the value set on solenoid "b", the control spool (2) is pushed back against the solenoid force and connects A with T until the set pressure is achieved again. The pressure is proportional to the solenoid current.

When the solenoid is switched off, the control spool (2) is returned to the central position by the compression springs (8).

Important:

Regarding valves of the version 3DREP 6 C, only one solenoid may be actuated at a time.

Type 3DREP 6..2X/..XE...

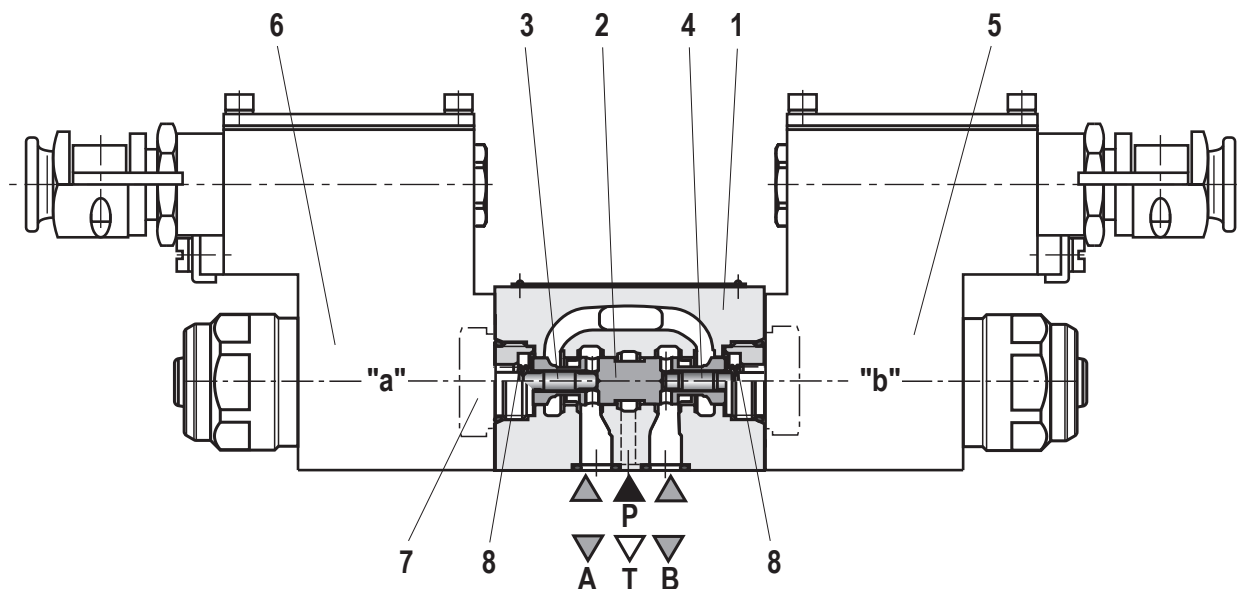

Valve with two spool positions

(Type 3DREP 6...A...)

The function of this valve version basically corresponds to the valve with three spool positions. This 2-spool position valve is, however, only equipped with solenoid "b" (5). Instead of the 2nd proportional solenoid, there is a plug screw (7).

Important:

The tank line must not be allowed to run empty. With corresponding installation conditions, a preload valve must be installed (preload pressure approx. 2 bar).

Technical data

General

Installation position	Any, preferably horizontal		
Storage temperature range	°C	-20... +50	
Ambient temperature range	°C	-20 ... +60	
Weight, maximum	Size 10	kg	10
	Size 16	kg	16
	Size 25	kg	21
	Size 32	kg	45
Surface protection	Galvanized		

Hydraulic

Size	size	10	16	25	32	
Operating pressure		30 ... 100				
Pilot control valve	External pilot oil supply	30 ... 100				
	Internal pilot oil supply	100 ... 315 only with "D3"	100 ... 350 only with "D3"			
Main valve	bar	up to 315	up to 350	up to 350	up to 350	
Return flow pressure	Port T (external pilot oil return)	bar	up to 315	up to 250	up to 250	up to 150
	Port T (internal pilot oil return)	bar	up to 30	up to 30	up to 30	up to 30
	Port Y	bar	up to 30	up to 30	up to 30	up to 30
Pilot volume for switching process 0 → 100%	cm ³	1.7	4.6	10	26.5	
Pilot flow at port X and Y with stepped input signal 0 → 100%	l/min	3.5	5.5	7	15.9	
Flow of the main valve	l/min	up to 170	up to 460	up to 870	up to 1600	
Hydraulic fluid		See table on page 7				
Hydraulic fluid temperature range	°C	-20 ... +80 (NBR seals)				
	°C	-15 ... +80 (FKM seals)				
Viscosity range	mm ² /s	20 ... 380 (preferably 30 ... 46)				
Max. admissible degree of contamination of the hydraulic fluid						
Cleanliness class according to ISO 4406 (c)	Pilot control valve	Class 17/15/12 ¹⁾				
	Main valve	Class 18/16/13 ¹⁾				
Hysteresis	%	≤ 6				

¹⁾ The cleanliness classes stated for the components need to be maintained in hydraulic systems. Effective filtration prevents faults and at the same time increases the service

life of the components. For the selection of the filters, see www.boschrexroth.com/filter.

Technical data

Hydraulic fluid	Classification	Suitable sealing materials	Standards
Mineral oils and related hydrocarbons	HL, HLP, HLPD, HVLP, HVLPD	NBR, FKM	DIN 51524
Bio-degradable	– insoluble in water	HETG	ISO 15380
		HEES	
	– soluble in water	HEPG	ISO 15380
Flame-resistant	– water-free	HFDU, HFDR	ISO 12922
	– containing water	HFC (Fuchs Hydrotherm 46M, Petrofer Ultra Safe 620)	ISO 12922



Important information about hydraulic fluids:

- There may be limitations regarding the technical valve data (temperature, pressure range, life cycle, maintenance intervals, etc.).
- Ignition temperature > 180 °C
- **Mineral oils and related hydrocarbons:**
 - If mineral oils and related hydrocarbons are used, data sheet 90220 must be complied with.
- **Bio-degradable:**
 - If bio-degradable hydraulic fluids are used, data sheet 90221 must be complied with.
- **Flame-resistant – not containing water:**
 - If flame-resistant, water-free hydraulic fluids are used, data sheet 90222 must be complied with.
- **Flame-resistant – containing water:**
 - Maximum pressure differential per control edge 50 bar
 - Pressure pre-loading at the tank port > 20% of the pressure differential, otherwise increased cavitation
 - Life cycle as compared to operation with mineral oil HL, HLP 50% ... 100%

Electrical

Voltage type		Direct current or pulse-width modulated signal with a pulse voltage ≤ 28 V and a frequency ≥ 160 Hz up to max. 500 Hz
Type of signal		Analog
Maximum current per solenoid	A	1.03
Duty cycle	%	100
Coil temperature	°C	up to 125

Information on the explosion protection

Area of application according to the explosion protection directive 94/9/EC	II 2G
Type of protection valve according to EN 13463-1:2009 / EN 13463-5:2011	c T4 X
Type of protection valve solenoid according to EN 60079-7:2007 / EN 60079-18:2009	Ex e mb IIC T4 Gb ¹⁾
Type examination certificate, solenoid	KEMA 02ATEX2240 X
"IECEX Certificate of Conformity" solenoid	IECEX DEK 12.0068X
Special application conditions for safe application	<ul style="list-style-type: none"> - In the case of a bank assembly, only one solenoid of all valves may be energized at a time. - In the case of valves with two solenoids, maximally one of the solenoids may be energized at a time. - Only direct current or a pulse-width modulated signal with a pulse voltage ≤ 28 V and frequency ≥ 160 Hz up to max. 500 Hz may be used.

Control electronics ²⁾

Amplifier module for the control of explosion-proof proportional directional valves 4WRA...XE, 3DREP 6...XE and 4WRZ...XE	VT-MSPA2-200-1X/V0/0 according to data sheet 30228-200
Module for monitoring and limiting the solenoid currents on proportional valves	VT-MUXA2-2-1X/V0/1A according to data sheet 30290

¹⁾ Surface temperature > 50 °C, provide contact protection

²⁾ **Important:**

A monitoring circuit is to be provided for the monitoring of the solenoid current. We recommend operating the valves with the assemblies described herein.

Electrical connection

The type-examination tested valve solenoid is equipped with a terminal box and a type-tested cable gland.

The connection is polarity-independent.

Important:

Corresponding to the rated current, a fuse according to DIN 41571 and EN / IEC 60127 has to be connected upstream of every valve solenoid (max. $3 \times I_{nom}$).

The shut-off threshold of the fuse has to match the prospective short-circuit current of the supply source.

The prospective short-circuit current of the supply source may amount to a maximum of 1500 A.

This fuse may only be installed outside the explosive area or must be of an explosion-proof design.

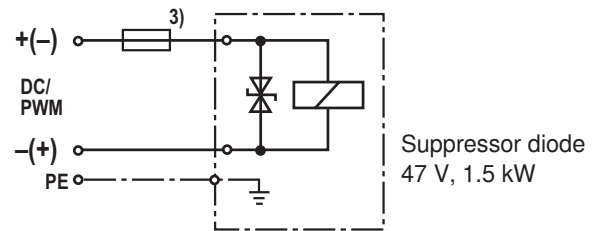
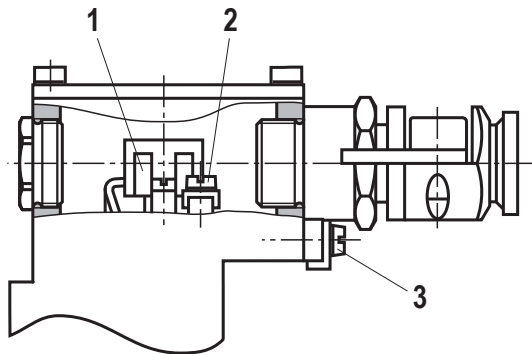

³⁾ Recommended pre-fuse

Characteristics: medium time-lag according to DIN 41571, 1.25 A

Properties of the connection terminals

Position	Function	Connectable line cross-section
1	Operating voltage connection	Single-wire 0.75 ... 2.5 mm ² Finely stranded 0.75 ... 1.5 mm ²
2	Connection for protective earthing conductor	Single-wire max. 2.5 mm ² Finely stranded max. 1.5 mm ²
3	Connection for potential equalization conductor	Single-wire 4 ... 6 mm ² Finely stranded 4 mm ²

Cable gland

Type approval	II 2G Ex e IIC Gb
Threaded connection	M20 x 1.5
Protection class according to EN 60529	IP66 ¹⁾
Line diameter	mm 9 ... 11
Sealing	Outer sheath sealing

Connection line

Line type	Non-armored cables and lines (outer sheath sealing)
Temperature range	°C -30 ... > +110

¹⁾ if installed properly

Characteristic curves, size 10

(measured with control spools E, W6-, EA, W6A as well as HLP46, $\vartheta_{oil} = 40\text{ °C} \pm 5\text{ °C}$)

Ordering code 25: flow

- 1 $\Delta p = 10$ bar constant
- 2 $\Delta p = 20$ bar constant
- 3 $\Delta p = 30$ bar constant
- 4 $\Delta p = 50$ bar constant
- 5 $\Delta p = 100$ bar constant

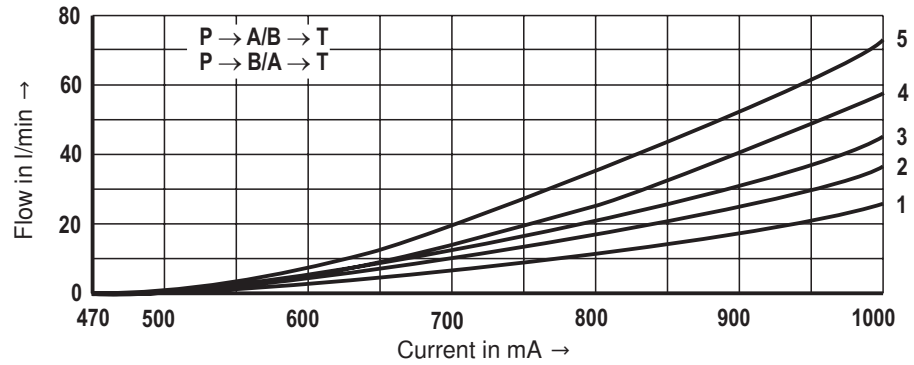

Ordering code 50: flow

- 1 $\Delta p = 10$ bar constant
- 2 $\Delta p = 20$ bar constant
- 3 $\Delta p = 30$ bar constant
- 4 $\Delta p = 50$ bar constant
- 5 $\Delta p = 100$ bar constant

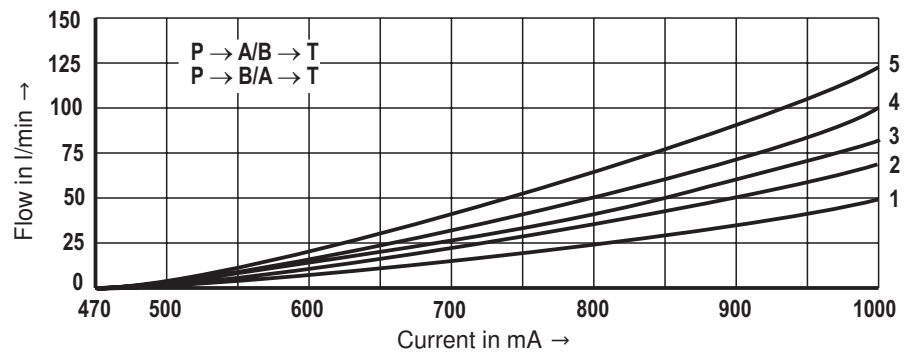

Ordering code 85: flow

- 1 $\Delta p = 10$ bar constant
- 2 $\Delta p = 20$ bar constant
- 3 $\Delta p = 30$ bar constant
- 4 $\Delta p = 50$ bar constant
- 5 $\Delta p = 100$ bar constant

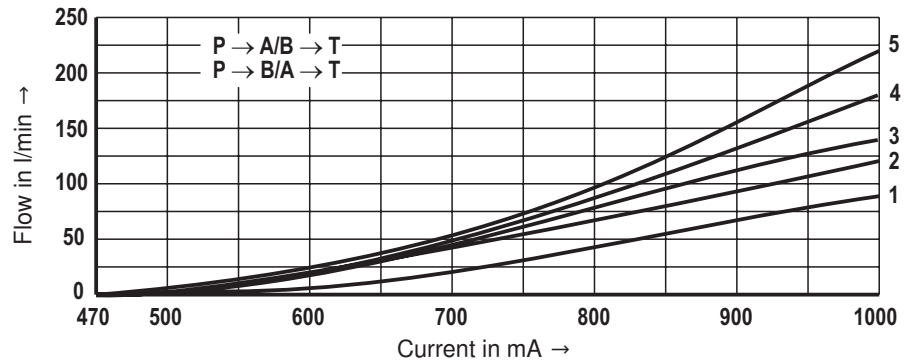

Δp = valve pressure differential according to DIN 24311 (inlet pressure p_p minus load pressure p_L minus return flow pressure p_T)

Transition function with stepped electric input signals

	Change of input signal [%]
1	0 → 25 → 0
2	0 → 50 → 0
3	0 → 75 → 0
4	0 → 100 → 0

Measured at pilot pressure $p_{ST} = 50$ bar

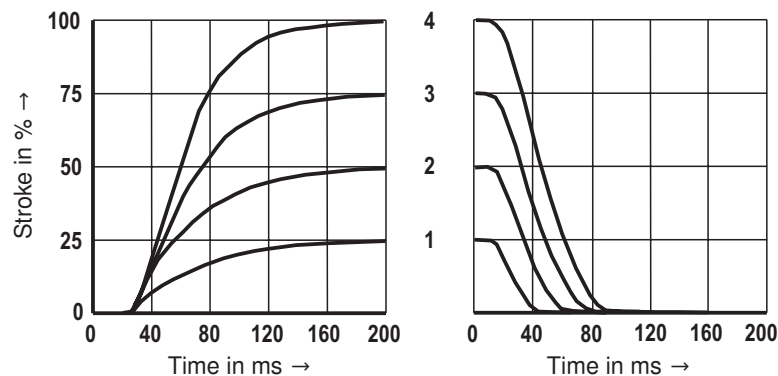

Characteristic curves, size 16

(measured with control spools E, W6-, EA, W6A as well as HLP46, $\vartheta_{oil} = 40 \text{ }^\circ\text{C} \pm 5 \text{ }^\circ\text{C}$)

Ordering code 100: flow

- 1 $\Delta p = 10$ bar constant
- 2 $\Delta p = 20$ bar constant
- 3 $\Delta p = 30$ bar constant
- 4 $\Delta p = 50$ bar constant
- 5 $\Delta p = 100$ bar constant

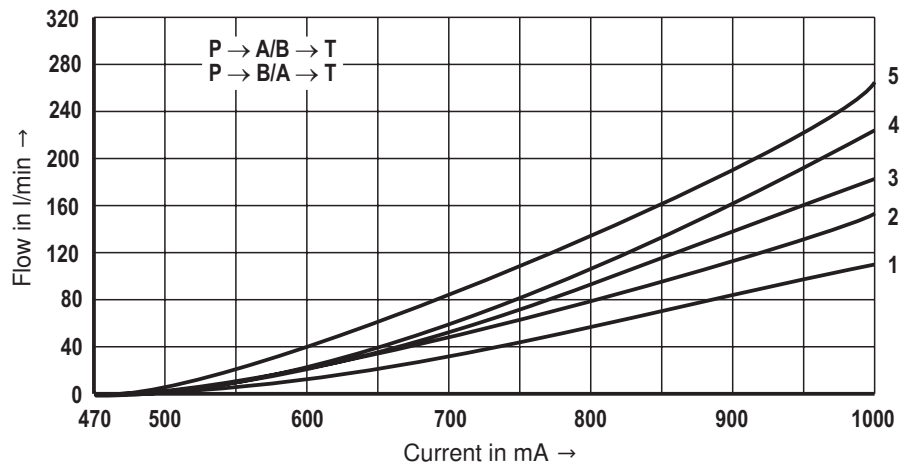

Ordering code 125: flow

- 1 $\Delta p = 10$ bar constant
- 2 $\Delta p = 20$ bar constant
- 3 $\Delta p = 30$ bar constant
- 4 $\Delta p = 50$ bar constant
- 5 $\Delta p = 100$ bar constant

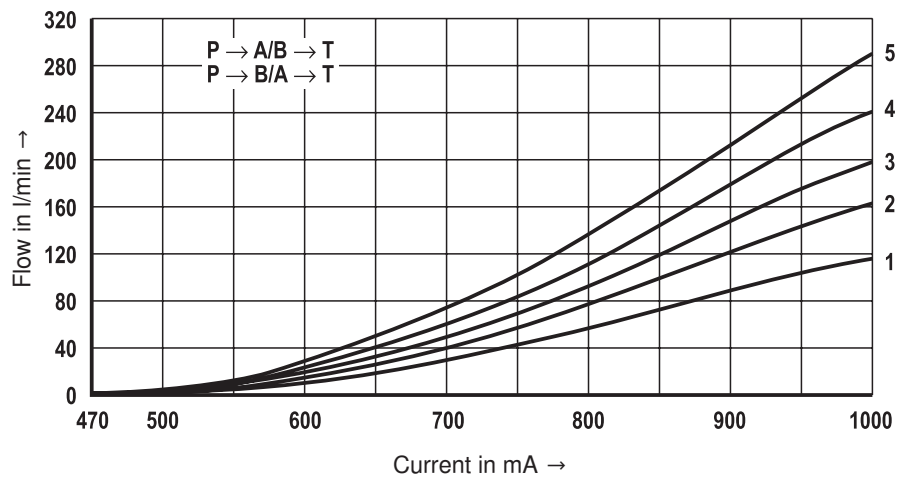

Ordering code 150: flow

- 1 $\Delta p = 10$ bar constant
- 2 $\Delta p = 20$ bar constant
- 3 $\Delta p = 30$ bar constant
- 4 $\Delta p = 50$ bar constant
- 5 $\Delta p = 100$ bar constant

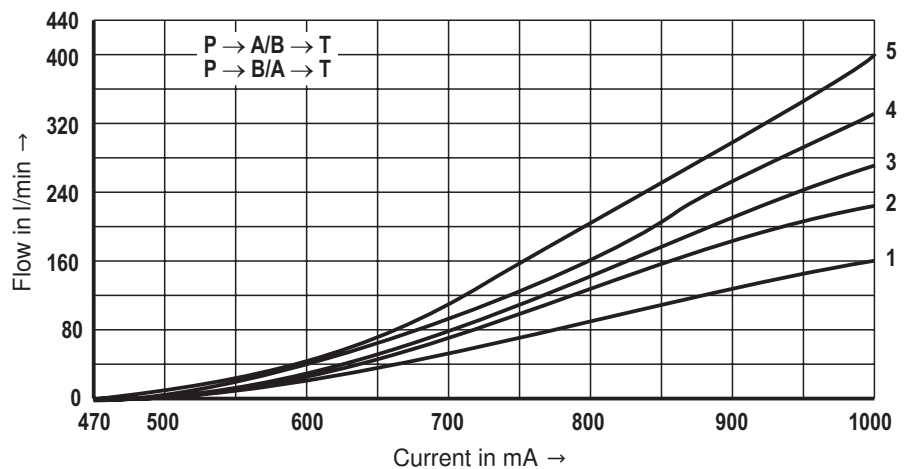

Characteristic curves, size 16

(measured with control spools E, W6-, EA, W6A as well as HLP46, $\vartheta_{oil} = 40 \text{ }^\circ\text{C} \pm 5 \text{ }^\circ\text{C}$)

Ordering code 180: flow

- 1 $\Delta p = 10 \text{ bar constant}$
- 2 $\Delta p = 20 \text{ bar constant}$
- 3 $\Delta p = 30 \text{ bar constant}$
- 4 $\Delta p = 50 \text{ bar constant}$
- 5 $\Delta p = 100 \text{ bar constant}$

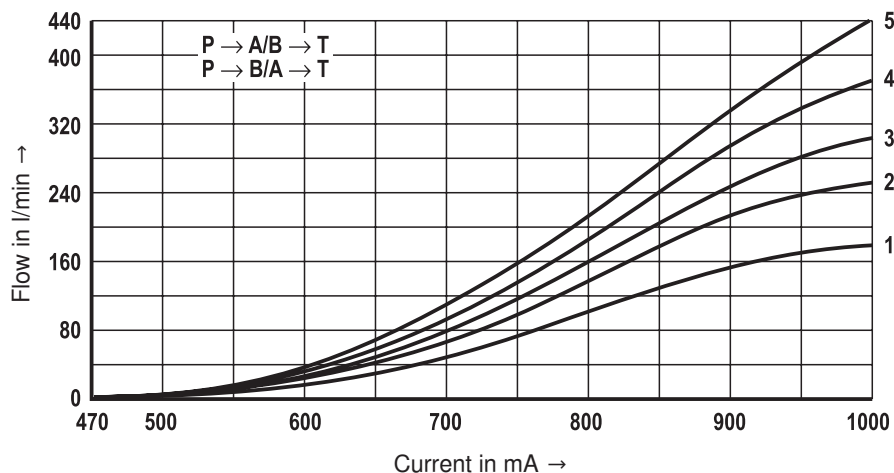

$\Delta p =$ valve pressure differential according to DIN 24311 (inlet pressure p_p minus load pressure p_L minus return flow pressure p_T)

Transition function with stepped electric input signals

	Change of input signal [%]
1	0 → 25 → 0
2	0 → 50 → 0
3	0 → 75 → 0
4	0 → 100 → 0

Measured at pilot pressure
 $p_{ST} = 50 \text{ bar}$

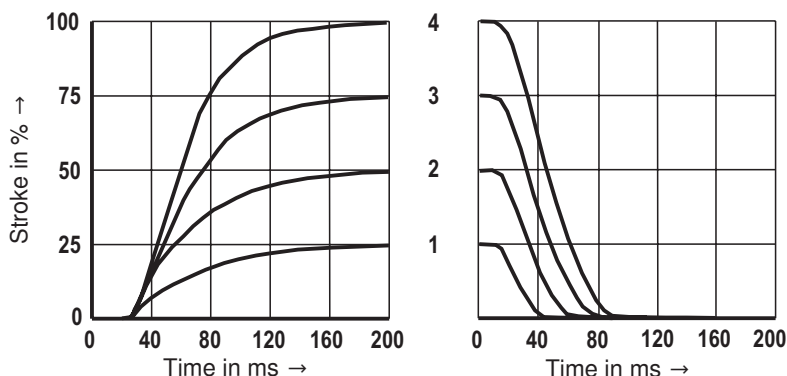

Characteristic curves, size 25

(measured with control spools E, W6-, EA, W6A as well as HLP46, $\vartheta_{\text{oil}} = 40 \text{ }^\circ\text{C} \pm 5 \text{ }^\circ\text{C}$)

Ordering code 220: flow

- 1 $\Delta p = 10 \text{ bar constant}$
- 2 $\Delta p = 20 \text{ bar constant}$
- 3 $\Delta p = 30 \text{ bar constant}$
- 4 $\Delta p = 50 \text{ bar constant}$
- 5 $\Delta p = 100 \text{ bar constant}$

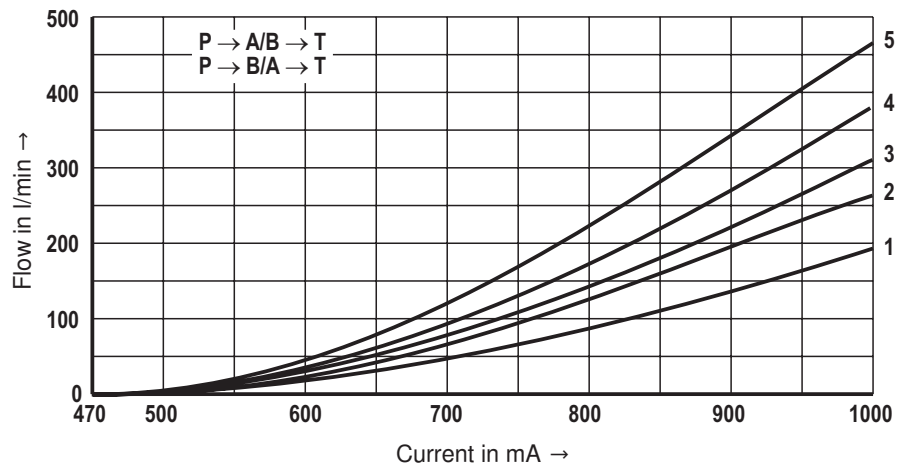

Ordering code 325: volume flow

- 1 $\Delta p = 10 \text{ bar constant}$
- 2 $\Delta p = 20 \text{ bar constant}$
- 3 $\Delta p = 30 \text{ bar constant}$
- 4 $\Delta p = 50 \text{ bar constant}$
- 5 $\Delta p = 100 \text{ bar constant}$

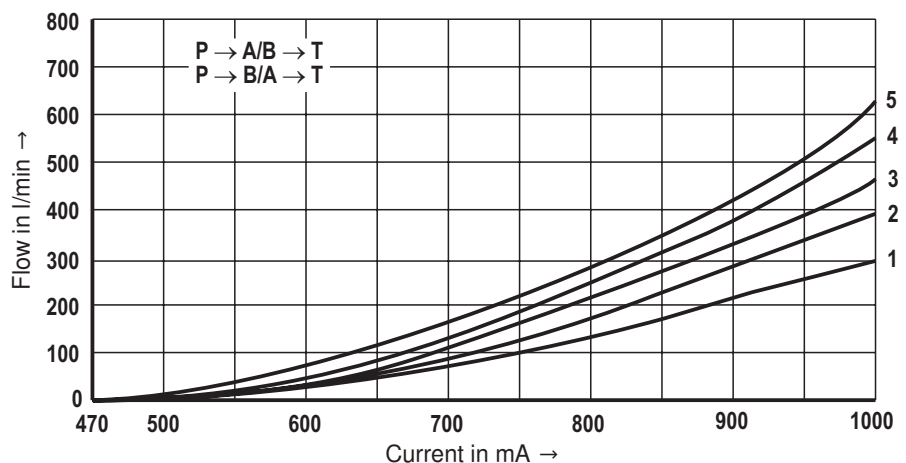

Δp = valve pressure differential according to DIN 24311 (inlet pressure p_p minus load pressure p_L minus return flow pressure p_T)

Transition function with stepped electric input signals

	Change of input signal [%]
1	0 → 25 → 0
2	0 → 50 → 0
3	0 → 75 → 0
4	0 → 100 → 0

Measured at pilot pressure
 $p_{\text{ST}} = 50 \text{ bar}$

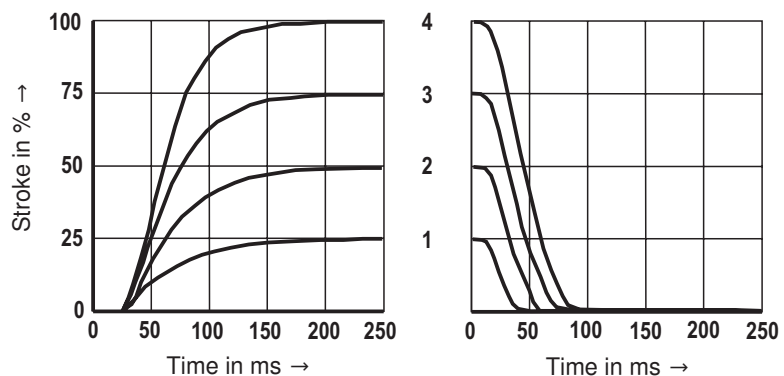

Characteristic curves, size 32

(measured with control spools E, W6-, EA, W6A as well as HLP46, $\vartheta_{oil} = 40 \text{ }^\circ\text{C} \pm 5 \text{ }^\circ\text{C}$)

Ordering code 360: flow

- 1 $\Delta p = 10 \text{ bar constant}$
- 2 $\Delta p = 20 \text{ bar constant}$
- 3 $\Delta p = 30 \text{ bar constant}$
- 4 $\Delta p = 50 \text{ bar constant}$
- 5 $\Delta p = 100 \text{ bar constant}$

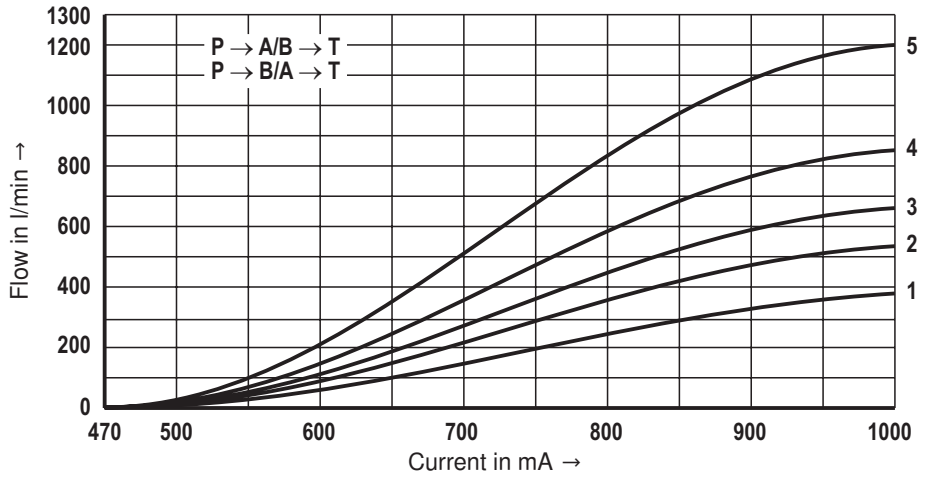

Ordering code 520: flow

- 1 $\Delta p = 10 \text{ bar constant}$
- 2 $\Delta p = 20 \text{ bar constant}$
- 3 $\Delta p = 30 \text{ bar constant}$
- 4 $\Delta p = 50 \text{ bar constant}$
- 5 $\Delta p = 100 \text{ bar constant}$

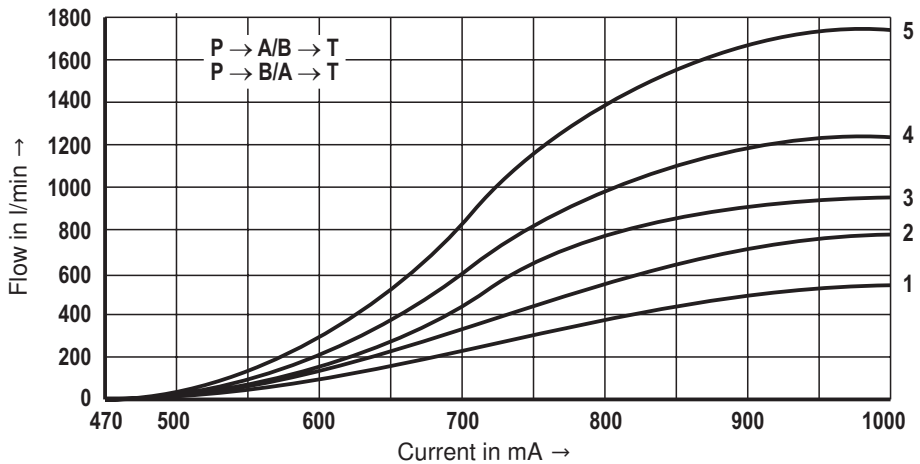

$\Delta p =$ valve pressure differential according to DIN 24311 (inlet pressure p_p minus load pressure p_L minus return flow pressure p_r)

Transition function with stepped electric input signals

	Change of input signal [%]
1	0 → 25 → 0
2	0 → 50 → 0
3	0 → 75 → 0
4	0 → 100 → 0

Measured at pilot pressure
 $p_{ST} = 50 \text{ bar}$

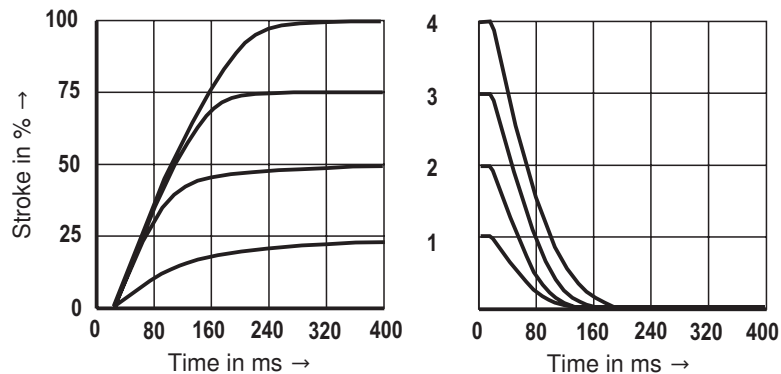

Dimensions, size 10 (dimensions in mm)

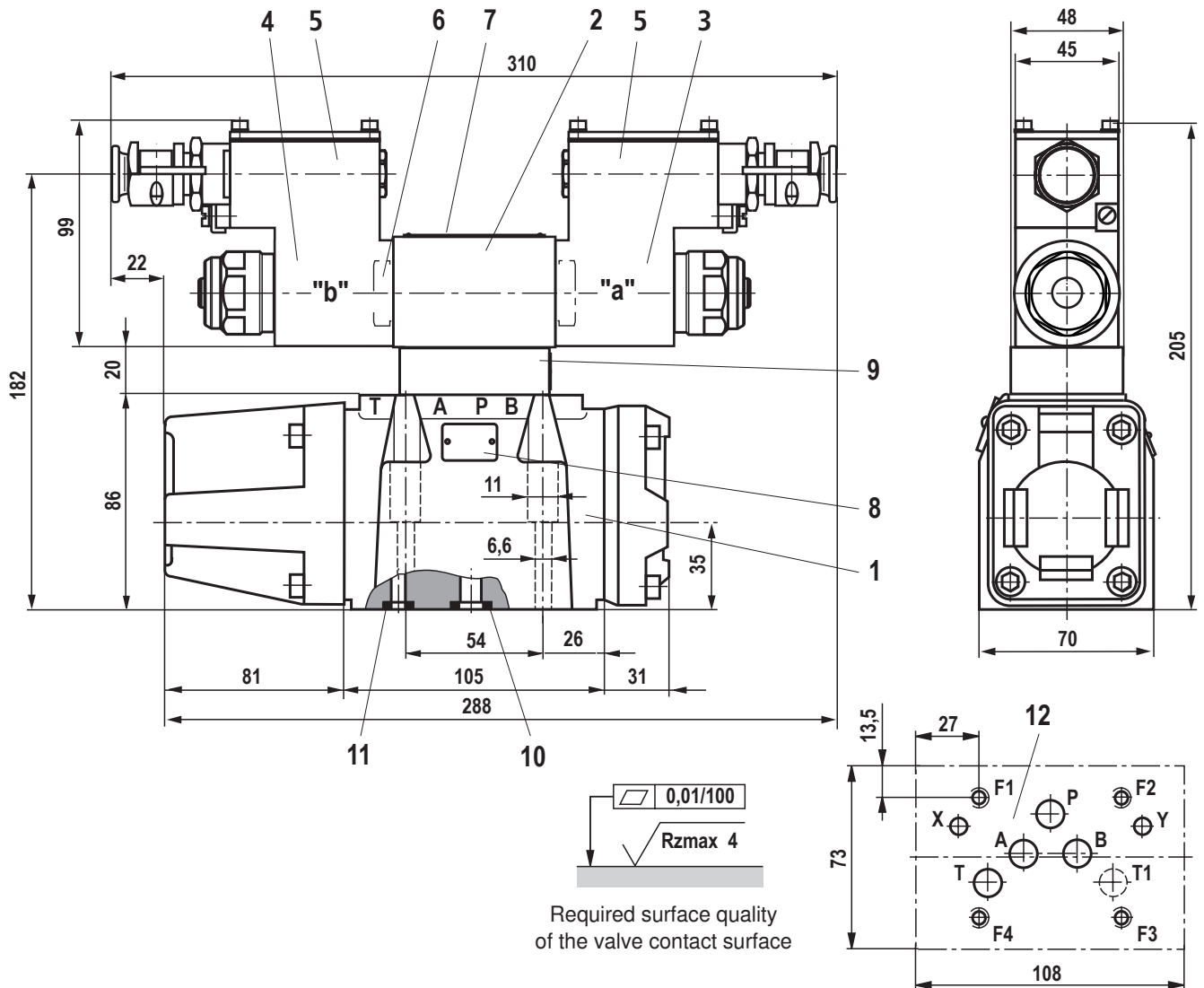

- 1 Main valve
- 2 Pilot control valve
- 3 Proportional solenoid "a"
- 4 Proportional solenoid "b"
- 5 Terminal box
- 6 Plug screw for valves with one solenoid
- 7 Name plate for pilot control valve
- 8 Name plate for main valve
- 9 Pressure reducing valve (always available)
- 10 Identical seal rings for ports P, A, B, T and T1
- 11 Identical seal rings for X and Y
- 12 Machined valve contact surface, porting pattern according to ISO 4401-05-05-0-05 (X, Y as required, T1 is available at the valve and can optionally be provided)

Deviating from the standard:
 – Locating pin not available

Subplates

G 534/01 FE/ZN (G3/4) **without** ports X and Y
 G 535/01 FE/ZN (G3/4) **with** ports X and Y
 G 536/01 FE/ZN (G1) **with** ports X and Y

Dimensions according to data sheet 45054 must be ordered separately.

Valve mounting screws

For reasons of stability, exclusively use the following valve mounting screws:

4 hexagon socket head cap screws

ISO 4762-M6x45-10.9-fZn-240h-L

(Total friction coefficient: 0.09-0.14 according to VDA 235-101)

(Must be ordered separately)

Important:

Subplates are not components in the sense of directive 94/9/EC and can be used after the manufacturer of the overall system has assessed the risk of ignition.

The G...FE/ZN versions are free from aluminum and/or magnesium and galvanized.

Dimensions, size 16 (dimensions in mm)

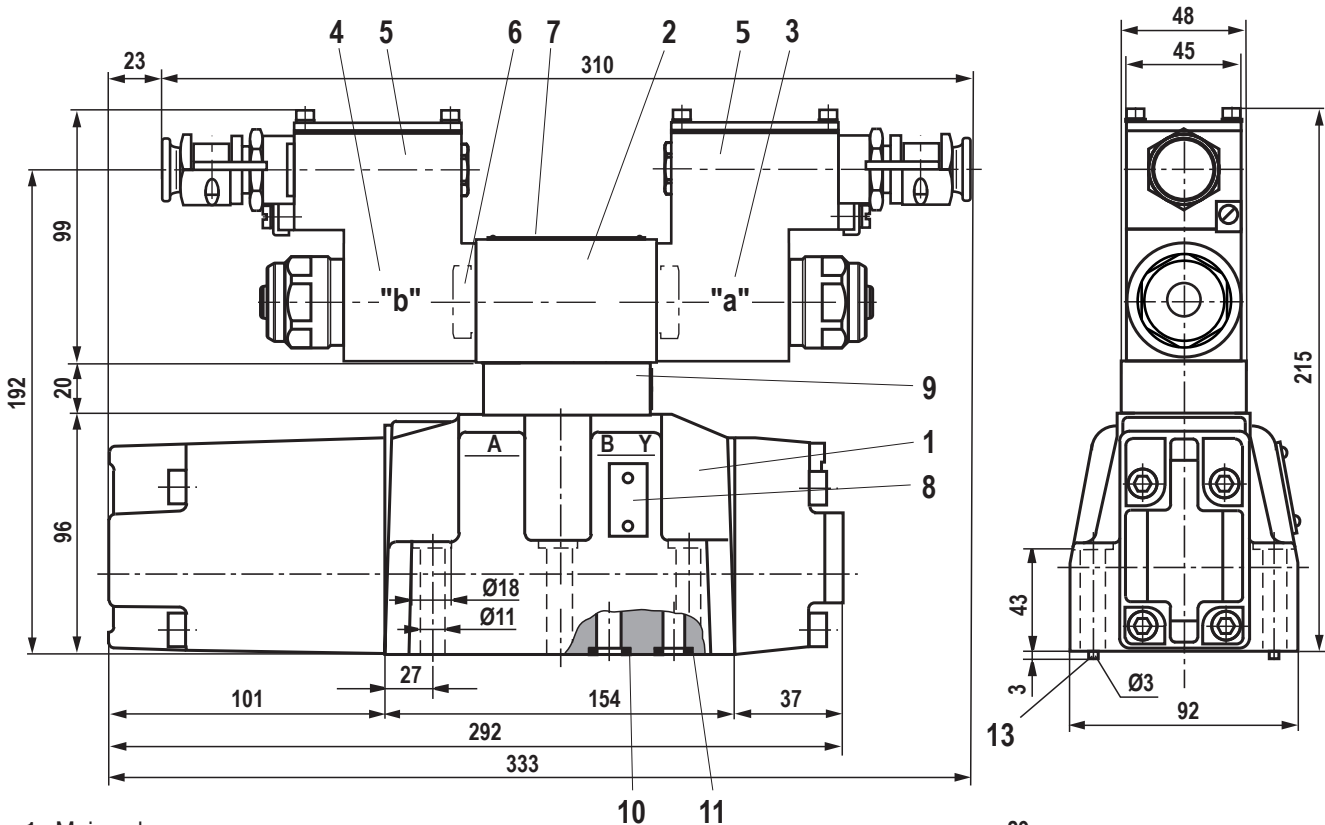

- 1 Main valve
- 2 Pilot control valve
- 3 Proportional solenoid "a"
- 4 Proportional solenoid "b"
- 5 Terminal box
- 6 Plug screw for valves with one solenoid
- 7 Name plate for pilot control valve
- 8 Name plate for main valve
- 9 Pressure reducing valve (always available)
- 10 Identical seal rings for ports P, A, B and T ¹⁾
- 11 Identical seal rings for X and Y
- 12 Machined valve contact surface, porting pattern according to ISO 4401-07-07-0-05 (X, Y as required)
 Deviating from the standard:
 - Ports P, A, B and T ²⁾ with Ø 20 mm
- 13 Locating pin

Subplates

G 172/01 FE/Zn (G3/4) G 172/02 FE/Zn (M27 x 2)
 G 174/01 FE/Zn (G1)
 G 174/02 FE/Zn (M33 x 2) G 174/08 FE/Zn (flange)
 Dimensions according to data sheet 45056 must be ordered separately.

¹⁾ without nominal flow of 100 l/min and 150 l/min
²⁾ with nominal flow of 100 l/min and 150 l/min T with Ø13 mm

Valve mounting screws

For reasons of stability, exclusively the following valve mounting screws are to be used:

2 hexagon socket head cap screws
ISO 4762-M6x60-10.9-fIZn-240h-L
(Total friction coefficient: 0.09-0.14 according to VDA 235-101)
 (Must be ordered separately)

4 hexagon socket head cap screws
ISO 4762-M10x60-10.9-fIZn-240h-L
(Total friction coefficient: 0.09-0.14 according to VDA 235-101)
 (Must be ordered separately)

Important:

Subplates are not components in the sense of directive 94/9/EC and can be used after the manufacturer of the overall system has assessed the risk of ignition.

The G...FE/Zn versions are free from aluminum and/or magnesium and galvanized.

Dimensions, size 25 (dimensions in mm)

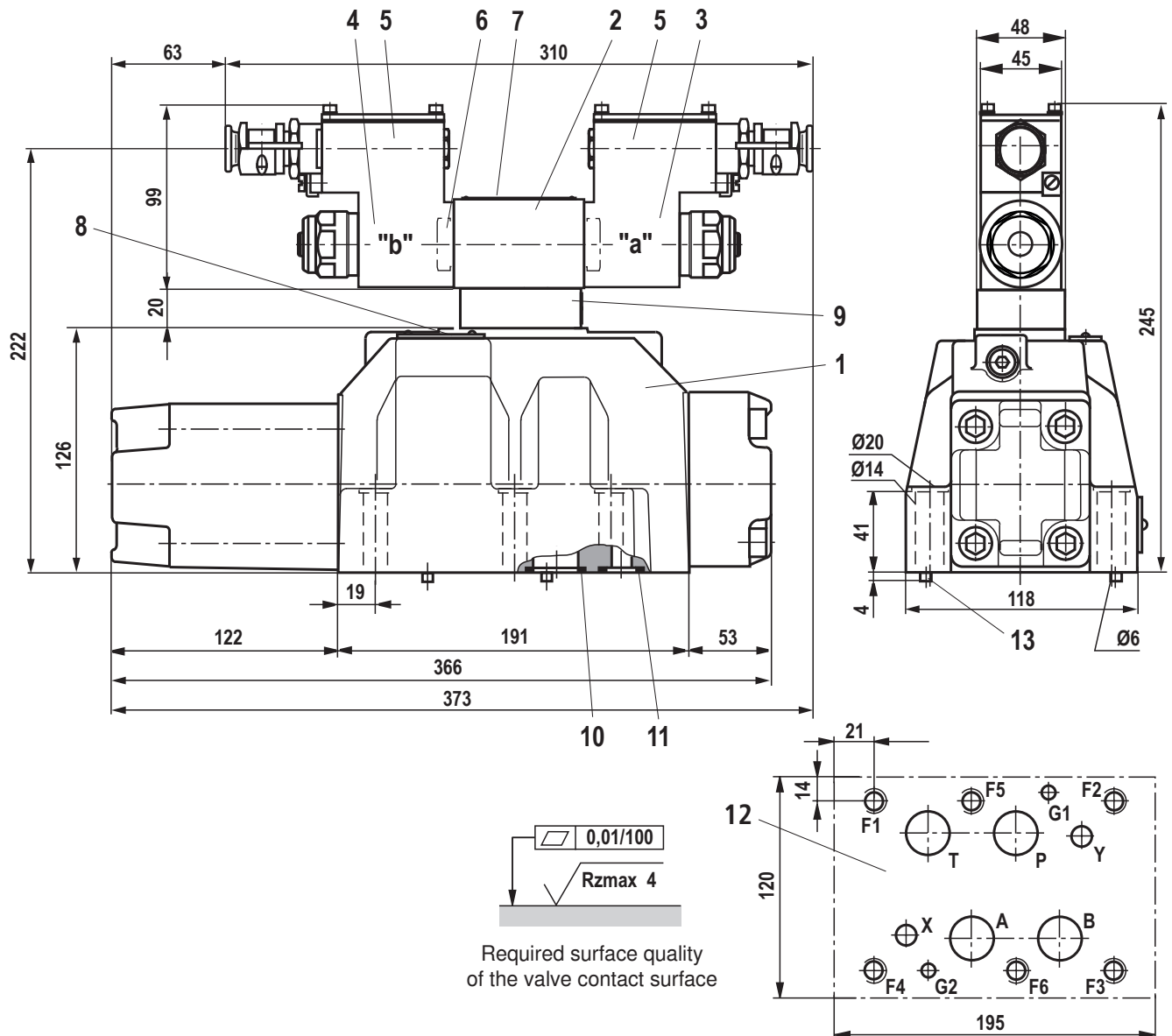

- 1 Main valve
- 2 Pilot control valve
- 3 Proportional solenoid "a"
- 4 Proportional solenoid "b"
- 5 Terminal box
- 6 Plug screw for valves with one solenoid
- 7 Name plate for pilot control valve
- 8 Name plate for main valve
- 9 Pressure reducing valve (always available)
- 10 Identical seal rings for ports P, A, B and T
- 11 Identical seal rings for X and Y
- 12 Machined valve contact surface, porting pattern according to ISO 4401-08-08-0-05 (X, Y as required)
- 13 Locating pin

Subplates

G 151/01 FE/ZN (G1)
 G 154/01 FE/ZN (G1 1/4) G 154/08 FE/ZN (flange)
 G 156/01 FE/ZN (G1 1/2)

Dimensions according to data sheet 45058 must be ordered separately.

Valve mounting screws

For reasons of stability, exclusively use the following valve mounting screws:

6 hexagon socket head cap screws
ISO 4762-M12x60-10.9-fIZn-240h-L
(Total friction coefficient: 0.09-0.14 according to VDA 235-101)
 (Must be ordered separately)

Important:

Subplates are not components in the sense of directive 94/9/EC and can be used after the manufacturer of the overall system has assessed the risk of ignition.

The G...FE/ZN versions are free from aluminum and/or magnesium and galvanized.

Dimensions, size 32 (dimensions in mm)

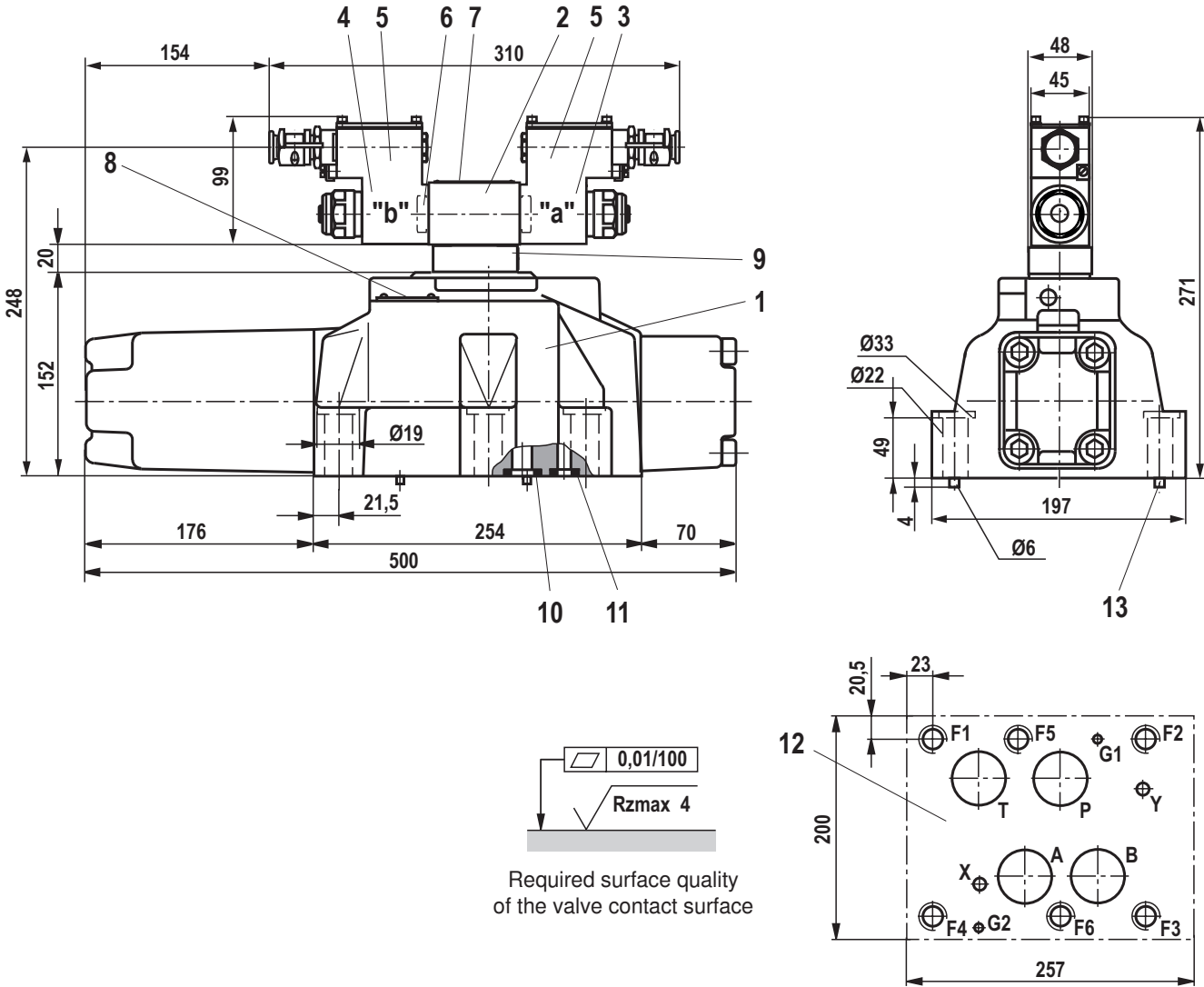

- 1 Main valve
- 2 Pilot control valve
- 3 Proportional solenoid "a"
- 4 Proportional solenoid "b"
- 5 Terminal box
- 6 Plug screw for valves with one solenoid
- 7 Name plate for pilot control valve
- 8 Name plate for main valve
- 9 Pressure reducing valve (always available)
- 10 Identical seal rings for ports P, A, B and T
- 11 Identical seal rings for X and Y
- 12 Machined valve contact surface, porting pattern according to ISO 4401-10-09-0-05 (X, Y as required)
 Deviating from the standard:
 - Ports P, A, B and T with Ø 38 mm
- 13 Locating pin

Subplates

- G 157/01 FE/Zn (G1 1/2)
- G 157/02 FE/Zn (M48 x 2)
- G 158/10 FE/Zn (flange)

Dimensions according to data sheet 45060 must be ordered separately.

Valve mounting screws

For reasons of stability, exclusively use the following valve mounting screws:

- 6 hexagon socket head cap screws**
- ISO 4762-M20x80-10.9-fZn-240h-L**
- (Total friction coefficient: 0.09-0.14 according to VDA 235-101)**
- (Must be ordered separately)

Important:

Subplates are not components in the sense of directive 94/9/EC and can be used after the manufacturer of the overall system has assessed the risk of ignition.

The G...FE/Zn versions are free from aluminum and/or magnesium and galvanized.

Pilot oil supply

Type 4WRZ...-.../...

External pilot oil supply External pilot oil return

In this version, the pilot oil is supplied from a separate control circuit (external).

The pilot oil return is not directed into the T channel of the main valve, but is separately directed to the tank via port Y (external).

Type 4WRZ...-.../...E...

Internal pilot oil supply External pilot oil return

In this version, the pilot oil is supplied via the P channel of the main valve (internal).

The pilot oil return is not directed into the T channel of the main valve, but is separately directed to the tank via port Y (external).

In the subplate, port X is to be closed.

Type 4WRZ...-.../...ET...

Internal pilot oil supply Internal pilot oil return

In this version, the pilot oil is supplied via the P channel of the main valve (internal).

The pilot oil is directly returned to channel T of the main valve (internal).

In the subplate, ports X and Y are closed.

Type 4WRZ...-.../...T...

External pilot oil supply Internal pilot oil return

In this version, the pilot oil is supplied from a separate control circuit (external).

The pilot oil is directly returned to channel T of the main valve (internal).

In the subplate, Y is to be closed.

Notes
